

Commercial status: Commercialised



Main

Range of product	Altivar Machine ATV320
Product or component type	Variable speed drive
Product specific application	Complex machines
Device short name	ATV320
Product destination	Synchronous motors Asynchronous motors
Format of the control block	Compact
EMC filter	Without EMC filter
IP degree of protection	IP20 conforming to IEC 61800-5-1 IP20 conforming to IEC 60529
Degree of protection	UL type 1 (with conformity kit)
Type of cooling	Fanless
Network number of phases	3 phases
[Us] rated supply voltage	200...240 V - 15...10 %
Supply frequency	50...60 Hz - 5...5 %
Motor power kW	0.37 kW for heavy duty
Motor power hp	0.5 hp for heavy duty
Line current	3.1 A at 200 V (heavy duty) 2.6 A at 240 V (heavy duty)
Prospective line I _{sc}	5 kA
Apparent power	1.1 kVA at 240 V (heavy duty)
Continuous output current	3.3 A at 4 kHz for heavy duty
Maximum transient current	5.0 A during 60 s (heavy duty)
Power range	0.37...0.55 kW at 200...240 V, 3 phases (based on load duty)
Asynchronous motor control profile	Voltage/Frequency ratio, 5 points Flux vector control without sensor, standard Voltage/Frequency ratio - Energy Saving, quadratic U/f Flux vector control without sensor - Energy Saving Voltage/frequency ratio, 2 points
Synchronous motor control profile	Vector control without sensor
Speed drive output frequency	0.1...599 Hz
Nominal switching frequency	4 kHz
Switching frequency	2...16 kHz adjustable 4...16 kHz with derating factor
Safety function	STO (safe torque off) SIL 3 SLS (safe limited speed) SS1 (safe stop 1) SMS (safe maximum speed) GDL (guard door locking)

The information provided in this documentation contains general descriptions and/or technical characteristics of the performance of the products contained herein. This documentation is not intended as a substitute for and is not to be used for determining suitability or reliability of these products for specific user applications. It is the duty of any such user or integrator to perform the appropriate and complete risk analysis, evaluation and testing of the products with respect to the relevant specific application or use thereof. Neither Schneider Electric Industries SAS nor any of its affiliates or subsidiaries shall be responsible or liable for misuse of the information contained herein.

Communication port protocol	Modbus serial CANopen
Optional communication modules	Communication module, CANopen daisy chain RJ45 Communication module, CANopen SUB-D 9 Communication module, CANopen open style terminal block Communication module, EtherCAT RJ45 Communication module, DeviceNet Communication module, Ethernet/IP Communication module, Profibus DP V1 Communication module, Profinet Communication module, Ethernet Powerlink

Complementary

Variant	Standard version
Output voltage	\leq power supply voltage
Permissible temporary current boost	1.5 x I _n during 60 s (heavy duty)
Speed range	1...100 for asynchronous motor in open-loop mode
Speed accuracy	+/- 10 % of nominal slip 0.2 T _n to T _n
Torque accuracy	+/- 15 %
Transient overtorque	170...200 % of nominal motor torque
Braking torque	\leq 170 % during 60 s with braking resistor
Regulation loop	Adjustable PID regulator
Motor slip compensation	Automatic whatever the load Adjustable 0...300 % Not available in voltage/frequency ratio (2 or 5 points)
Acceleration and deceleration ramps	Linear U S CUS Ramp switching Acceleration/Deceleration ramp adaptation Acceleration/deceleration automatic stop with DC injection
Braking to standstill	By DC injection
Protection type	Input phase breaks: drive Overcurrent between output phases and earth: drive Overheating protection: drive Short-circuit between motor phases: drive Thermal protection: drive
Frequency resolution	Display unit: 0.1 Hz Analog input: 0.012/50 Hz
Electrical connection	Screw terminal, clamping capacity: 0.5...1.5 mm ² , AWG 20...AWG 16 (control) Screw terminal, clamping capacity: 2.5...4 mm ² , AWG 14...AWG 12 (motor/braking resistor) Screw terminal, clamping capacity: 2.5...6 mm ² , AWG 14...AWG 10 (motor/braking resistor) Screw terminal, clamping capacity: 2.5...4 mm ² , AWG 14...AWG 12 (power supply) Screw terminal, clamping capacity: 2.5...6 mm ² , AWG 14...AWG 10 (power supply)
Connector type	1 RJ45 (on terminal) for Modbus/CANopen
Physical interface	2-wire RS 485 for Modbus serial/CANopen
Transmission frame	RTU for Modbus serial
Transmission rate	4.8, 9.6, 19.2, 38.4 kbit/s for Modbus serial 50 kbps, 125 kbps, 250 kbps, 500 kbps, 1 Mbps for CANopen
Data format	8 bits, configurable odd, even or no parity for Modbus serial
Type of polarization	No impedance for Modbus serial
Number of addresses	1...127 for CANopen 1...247 for Modbus serial
Method of access	Slave CANopen
Supply	Internal supply for reference potentiometer (1 to 10 kOhm): 10.5 V DC +/- 5 %, <10 mA, protection type: overload and short-circuit protection
Local signalling	1 LED (green)CANopen run: 1 LED (red)CANopen error: 1 LED (red)drive fault:
Width	72.0 mm
Height	143.0 mm

Depth	128.0 mm
Net weight	0.9 kg
Analogue input number	3
Analogue input type	AI1 voltage: 0...10 V DC, impedance: 30000 Ohm, resolution 10 bits AI2 bipolar differential voltage: +/- 10 V DC, impedance: 30000 Ohm, resolution 10 bits AI3 current: 0...20 mA (or 4-20 mA, x-20 mA, 20-x mA or other patterns by configuration), impedance: 250 Ohm, resolution 10 bits
Discrete input number	7
Discrete input type	Programmable (sink/source) (DI1...DI4)24...30 V DC, with level 1 PLC Programmable as pulse input 20 kpps (DI5)24...30 V DC, with level 1 PLC Switch-configurable PTC probe (DI6)24...30 V DC Safe torque off (STO)24...30 V DC - 1500 Ohm
Discrete input logic	Negative logic (sink) (DI1...DI6), > 19 V (state 0), < 13 V (state 1) Positive logic (source) (DI1...DI6), < 5 V (state 0), > 11 V (state 1)
Analogue output number	1
Analogue output type	AQ1 software-configurable current: 0...20 mA, impedance: 800 Ohm, resolution 10 bits AQ1 software-configurable voltage: 0...10 V, impedance: 470 Ohm, resolution 10 bits
Sampling duration	2 Ms (AI1, AI2, AI3) - analog input 2 ms (AQ1) - analog output
Accuracy	+/- 0.2 % AI1, AI2, AI3 for a temperature of -10...60 °C analog input +/- 0.5 % AI1, AI2, AI3 for a temperature of 25 °C analog input +/- 1 % AQ1 for a temperature of 25 °C analog output +/- 2 % AQ1 for a temperature of -10...60 °C analog output
Linearity error	AI1, AI2, AI3: +/- 0.2...0.5 % of maximum value for analog input AQ1: +/- 0.3 % for analog output
Discrete output number	3
Discrete output type	Configurable relay logic: (R1A, R1B, R1C) NO/NC - 100000 cycles Configurable relay logic: (R2A, R2B) NO - 100000 cycles Logic: (LO)
Refresh time	Logic input (DI1...DI6): 8 ms (+/- 0.7 ms) Relay output (R1A, R1B, R1C): 2 ms Relay output (R2A, R2C): 2 ms
Minimum switching current	Relay output R1, R2: 5 mA at 24 V DC
Maximum switching current	Relay output R1 on resistive load, cos phi = 1: 3 A at 250 V AC Relay output R1 on resistive load, cos phi = 1: 4 A at 30 V DC Relay output R1, R2 on inductive load, cos phi = 0.4: 2 A at 250 V AC Relay output R1, R2 on inductive load, cos phi = 0.4: 2 A at 30 V DC Relay output R2 on resistive load, cos phi = 1: 5 A at 250 V AC Relay output R2 on resistive load, cos phi = 1: 5 A at 30 V DC
Specific application	Machinery
Variable speed drive application selection	Hoisting Self erecting Material handling Carousel Material handling Conveyor Material handling Lifting platform Material handling Palletizers - medium performance Material handling Transfer table Material handling Turn table Material working (wood, ceramic, stone, pvc, metal) Cutting - medium accuracy Material working (wood, ceramic, stone, pvc, metal) Drilling Material working (wood, ceramic, stone, pvc, metal) Saw Packaging Bagging Packaging Feed conveyor low performance Packaging Filling bottles - intermittent operation Packaging Linear labeling Packaging Other application Packaging Stretching wrapping Packaging Tray take Textile Knitting Textile Printing machines Textile Spinning Washing machines Car Washing machines Other application Hoisting Standard crane - travelling or trolley
Motor power range	0.37...0.55 kW at 200...240 V 3 phases
Motor starter type	Variable speed drive

Environment

Isolation	Between power and control terminals
Insulation resistance	> 1 MOhm 500 V DC for 1 minute to earth
Noise level	0.0 dB conforming to 86/188/EEC
Power dissipation in W	Self-cooled: 33.9 W at 200 V, switching frequency 4 kHz
Operating position	Vertical +/- 10 degree
Electromagnetic compatibility	1.2/50 µs - 8/20 µs surge immunity test level 3 conforming to IEC 61000-4-5 Conducted radio-frequency immunity test level 3 conforming to IEC 61000-4-6 Electrical fast transient/burst immunity test level 4 conforming to IEC 61000-4-4 Electrostatic discharge immunity test level 3 conforming to IEC 61000-4-2 Radiated radio-frequency electromagnetic field immunity test level 3 conforming to IEC 61000-4-3 Voltage dips and interruptions immunity test conforming to IEC 61000-4-11
Pollution degree	2 conforming to EN/IEC 61800-5-1 3 conforming to EN/IEC 61800-5-1
Vibration resistance	1 gn (f= 13...200 Hz) conforming to EN/IEC 60068-2-6 1.5 mm peak to peak (f= 2...13 Hz) conforming to EN/IEC 60068-2-6
Shock resistance	15 gn for 11 ms conforming to EN/IEC 60068-2-27
Relative humidity	5...95 % without condensation conforming to IEC 60068-2-3 5...95 % without dripping water conforming to IEC 60068-2-3
Ambient air temperature for operation	-10...50 °C without 50...60 °C with derating factor
Ambient air temperature for storage	-25...70 °C
Operating altitude	<= 1000 m without 1000...3000 m with current derating 1 % per 100 m
Environmental characteristic	Chemical pollution resistance class 3C3 conforming to EN/IEC 60721-3-3 Dust pollution resistance class 3S2 conforming to EN/IEC 60721-3-3
Standards	EN/IEC 61800-3 Environment 2 category C3 EN/IEC 61800-3 EN/IEC 61800-5-1 IEC 61000-3-12 IEC 60721-3 IEC 61508 IEC 13849-1
Product certifications	CE ATEX NOM EAC RCM KC
Marking	CE ATEX UL CSA EAC RCM KC

Offer Sustainability

Sustainable offer status	Green Premium product
EU RoHS Directive	Pro-active compliance (Product out of EU RoHS legal scope) EU RoHS Declaration
Mercury free	Yes
RoHS exemption information	Yes
China RoHS Regulation	China RoHS Declaration
Environmental Disclosure	Product Environmental Profile
Circularity Profile	End Of Life Information
WEEE	The product must be disposed on European Union markets following specific waste collection and never end up in rubbish bins

Contractual warranty

Warranty	18 mois
----------	---------

Dimensions

Right View, Front View and Front View with EMC Plate

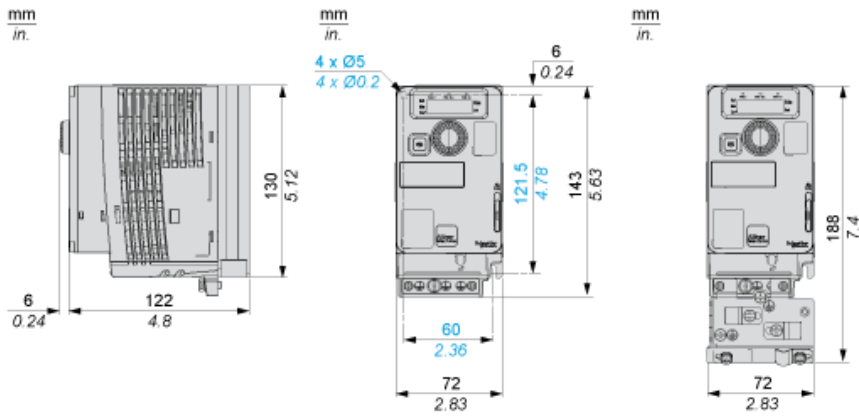

Mounting Types

Mounting Type A: Individual with Ventilation Cover

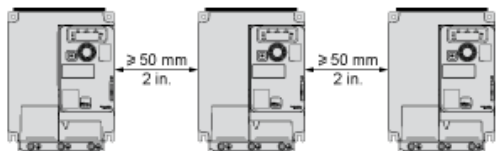

Only Possible at Ambient Temperature Less or Equal to 50 °C (122 °F)

Mounting Type B: Side by Side, Ventilation Cover Removed

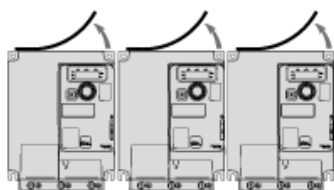

Mounting Type C: Individual, Ventilation Cover Removed

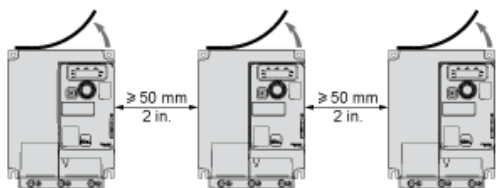

For Operation at Ambient Temperature Above 50 °C (122 °F)

Connection Diagrams

Diagram with Line Contactor

Connection diagrams conforming to standards ISO13849 category 1 and IEC/EN 61508 capacity SIL1, stopping category 0 in accordance with standard IEC/EN 60204-1.



- (1) Line choke (if used)
- (2) Fault relay contacts, for remote signaling of drive status

Diagram with Switch Disconnect

Connection diagrams conforming to standards EN 954-1 category 1 and IEC/EN 61508 capacity SIL1, stopping category 0 in accordance with standard IEC/EN 60204-1.



- (1) Line choke (if used)
- (2) Fault relay contacts, for remote signaling of drive status

Control Connection Diagram in Source Mode



- (1) Analog output
- (2) Analog inputs
- (3) Reference potentiometer (10 kOhm maxi)
- (4) Digital inputs

Digital Inputs Wiring

The logic input switch (SW1) is used to adapt the operation of the logic inputs to the technology of the programmable controller outputs. Switch SW1 set to “Source” position and use of the output power supply for the DIs.



Switch SW1 set to “Source” position and use of an external power supply for the DIs.



Switch SW1 set to “Sink Int” position and use of the output power supply for the DIs.

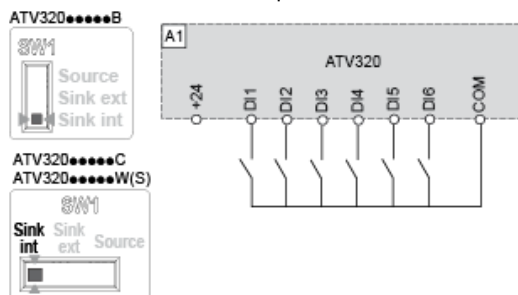

Switch SW1 set to "Sink Ext" position and use of an external power supply for the DIs.



Derating Curves

